

# ASSEMBLING FOR "TRIADE" AND "TRIADE MINI" WITH ALUMINIUM PROFILE (P/N 690240000)

**BEST  
OPTION**

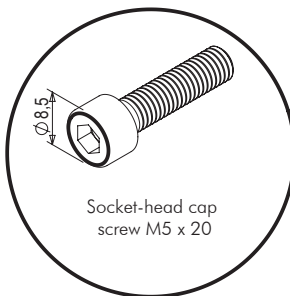

**USE A S4mm ALLEN WRENCH**

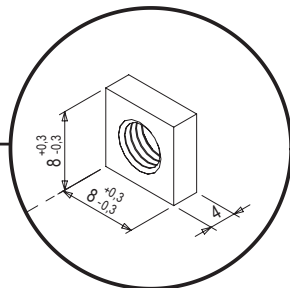
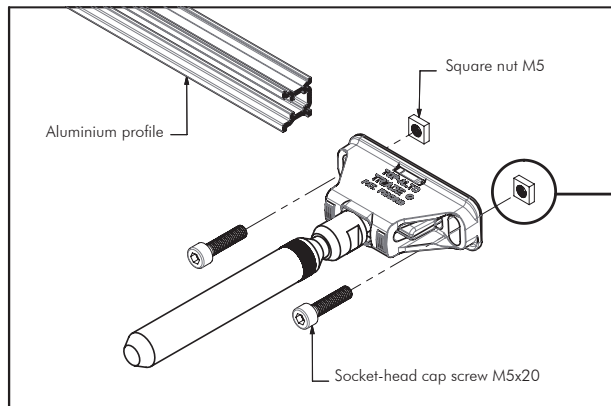
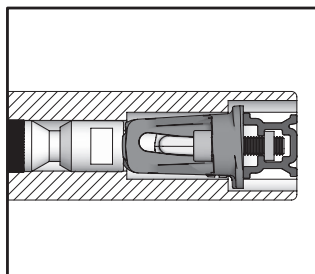
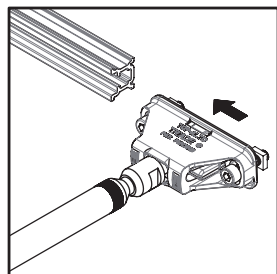

## DRILLING PLAN FOR "TRIADE"

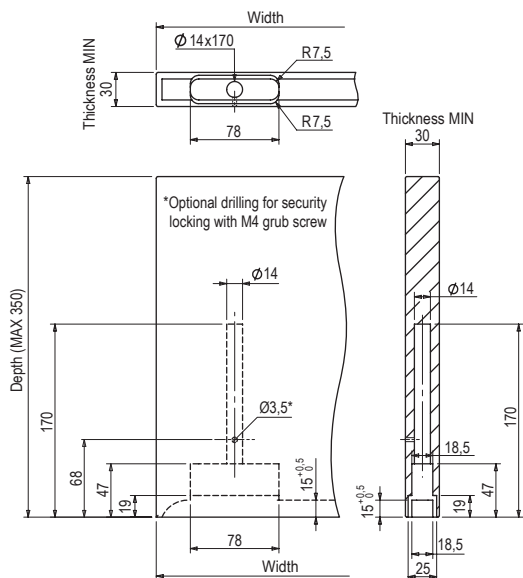

## DRILLING PLAN FOR "TRIADE MINI"

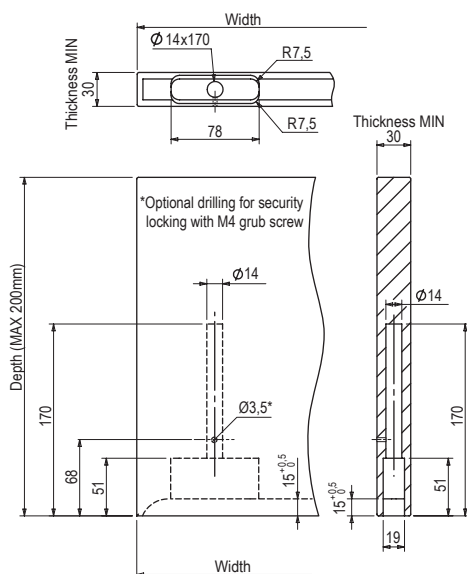

# ASSEMBLING FOR "TRIADE MAXI" AND "TRIADE XXL" WITH ALUMINIUM PROFILE (P/N 691240000)

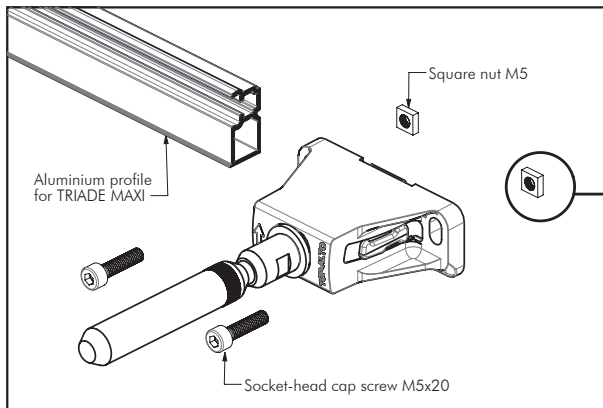

**BEST  
OPTION**

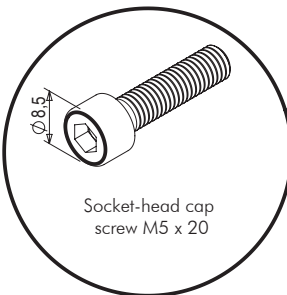
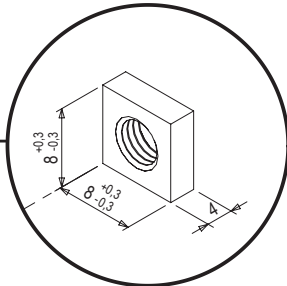

Socket-head cap  
screw M5 x 20

**USE A S4mm ALLEN WRENCH**

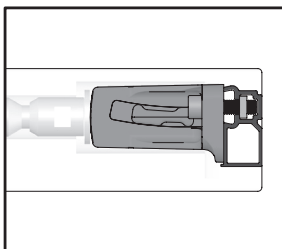
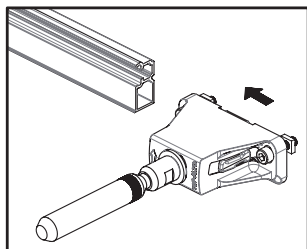

## DRILLING PLAN FOR "TRIADE MAXI"

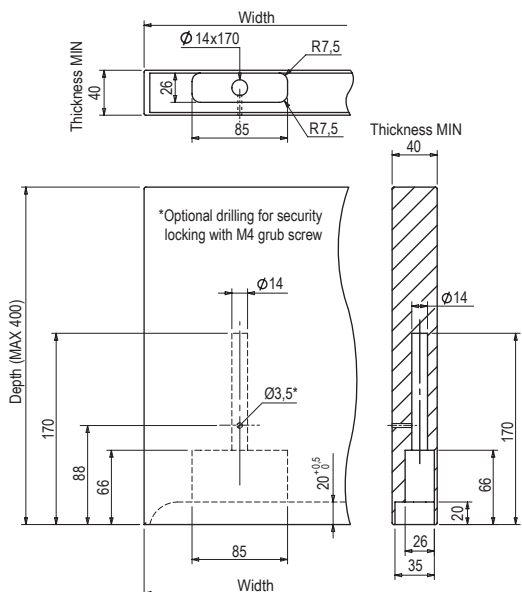

## DRILLING PLAN FOR "TRIADE XXL"

